

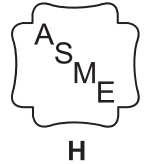

Submittal Sheet
Model GT 530A-20
Cast Iron Boiler



Project Name	
Project location	
Contractor	
Engineering Firm	
Boiler Representative	
Sales Rep. Phone	
Date Created	

Boiler Model		Burner Model	
Assembled		Burner Included	
Relief Valve		Fuel Type	
Boiler Options		Burner Options	
Code			

Revision

1		Date:	4		Date:
2		Date:	5		Date:
3		Date:	6		Date:

Engineering Submittal Package for GT 530A-20 Series

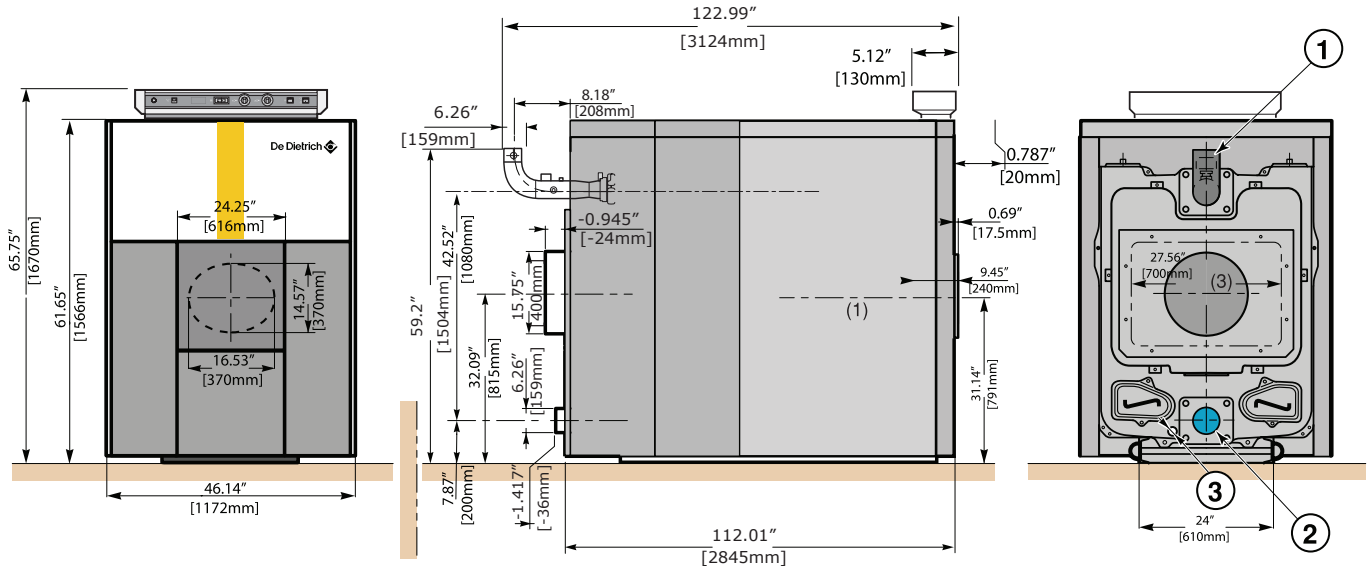

- ① Boiler supply, 5" ANSI 150#
- ② welded neck flange Boiler return, 5" ANSI 150#
- ③ welded neck flange Drain, 3/4" NPT

F*- Nominal length. Consult vent supplier for correct sizing.
 G*- Length required for clearing the water distributing tube.
 K*- Dimension representing the end of the 4"/100mm long chimney connection.

Boiler must not be installed on combustible flooring or pad, do not install on carpet.

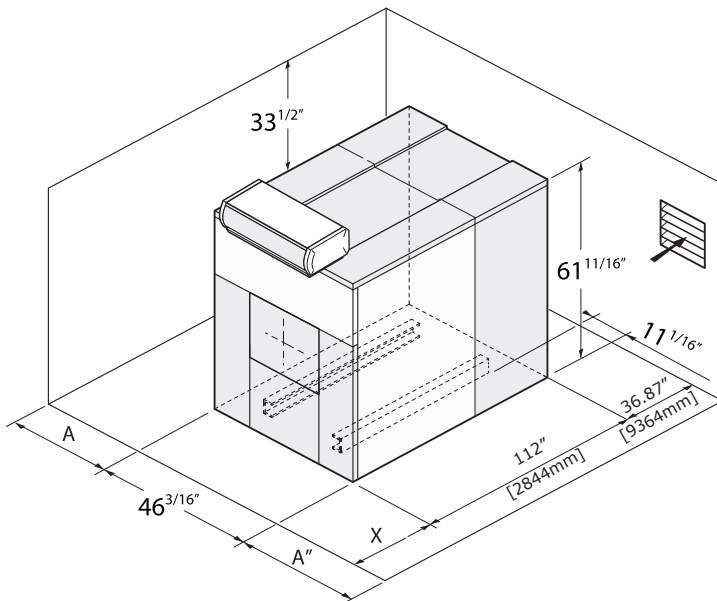

If A = 47 1/4" (side burner side door open),
A' = 47 1/4" (side burner door open): dimensions to be adopted according to the space required for the burner when the door is open.
 Dimensions "X" = burner length plus 24 inches for service

Engineering Submittal Package for GT 530A-20 Series

Boiler Specifications		
Input (Gas)	MBH/kW	4,975/1,458
Input (Oil)	US/GPH	34.50
Output (Gas-Oil)	MBH/kW	4.239/1,242.3
Cast Iron Sections	-	20
Flue-way Baffles	-	8
Water Capacity	USGAL/L	239.10/905
Water Resistance $\Delta T=18^{\circ}F$	Feet of Water (FT)/mbar	2.00/59.77
Water Resistance $\Delta T=27^{\circ}F$	Feet of Water (FT)/mbar	0.89/26.57
Water Resistance $\Delta T=36^{\circ}F$	Feet of Water (FT)/mbar	0.50/14.95
Combustion Chamber Dimensions (Diameter)	Inch/mm	27.32/694
Combustion Chamber Dimensions (Depth)	Inch/mm	86.18/2,189
Combustion Chamber Dimensions (Volume)	Ft ³ /m ³	29.66/0.84
ASME MAWP (Water)	PSI	ASME IV Rating Class 30-90 PISG
Minimum Relief Valve Capacity	MBH	4,652
Panel (Electrical Connection)	V/P/H	120/1/60 <10A
Panel (Maximum Water Temperature)	$^{\circ}F/^{\circ}C$	248/120
Panel (Operating Water Temperature Range)	$^{\circ}F/^{\circ}C$	104-212/ 40-100
Chamber Resistance	Inch w.c./mbar	1.21/3
Gas-Vent Category	-	I,II,III,IV or Sidewall
Boiler Vent Connection	Inch	16
Weight (Dry)	LB/kg	9,575/4,343