

#### 4.3.4.b Dimensions with bottom connection kit accessory

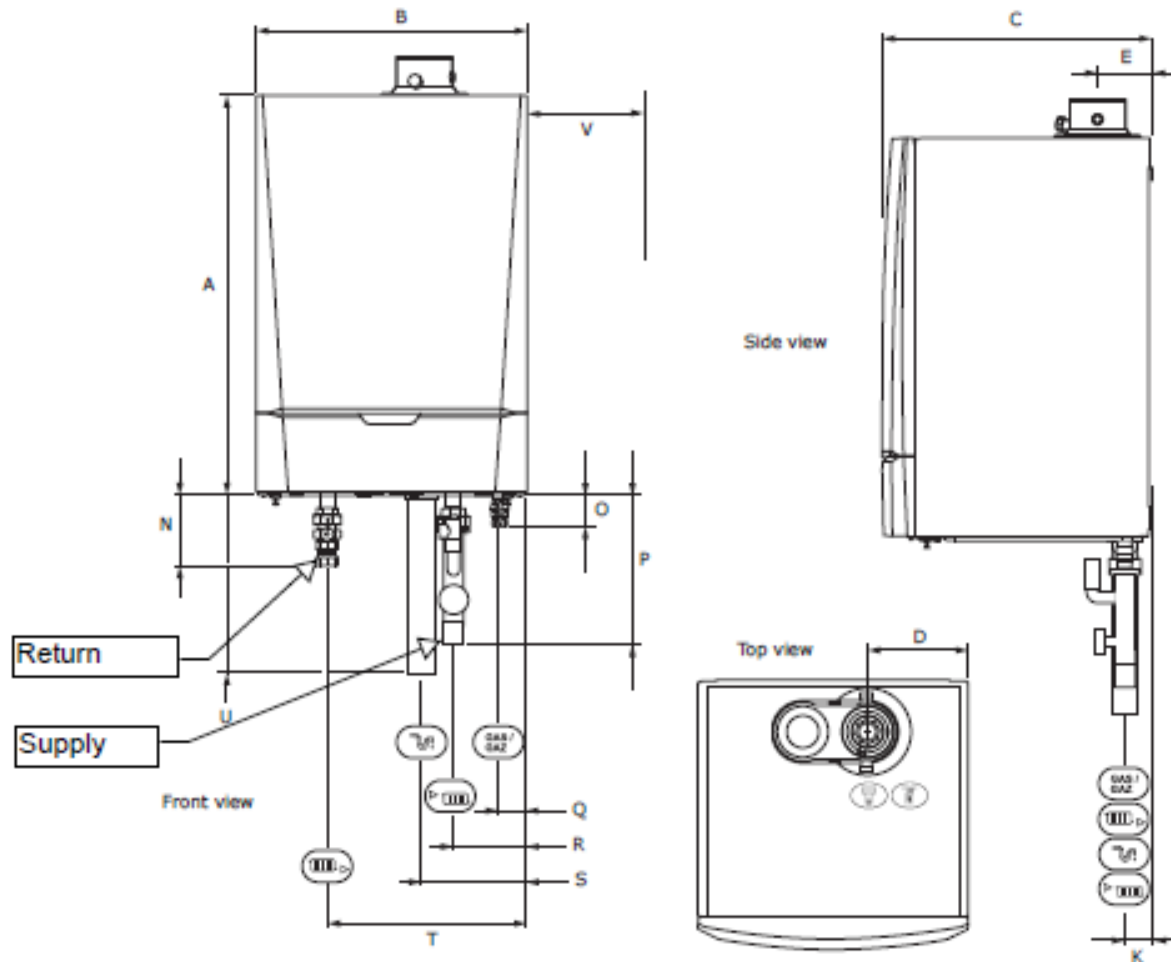

MCA Pro		inch/mm
A	Height	29½/750
B	Width	19¼/500
C	Depth	19¼/500
D	Right side/vent	7½/191
E	Back/vent	4/100
K	Back/center of pipe	2/50
N	Pipe length of G and H	5¾/135
O	Pipe length of F and J	2¾/60
P	Supply pipe length	11½/282
Q	Right side/gas pipe	2/50
R	Right side/supply pipe	5½/130
S	P-trap	7½/191
T	Right side/return pipe	14¾/365
U	P-trap length	13¾/335
V	Distance between boilers	12/300

	Connection of the vent pipe; 3"/80mm (MCA Pro 35/45), 4"/100mm (MCA Pro 65/90/115)
	Connection of the combustion air pipe; 3"/80mm (MCA Pro 35/45), 4"/100mm (MCA Pro 65/90/115)
	P-trap
	Heating circuit return pipe; 1½" Male thread (NPT)
<b>GAS</b>	Gas connection; ¾" Male thread (NPT)
	Heating circuit supply pipe; 1½" Male thread (NPT)